

**Top View**

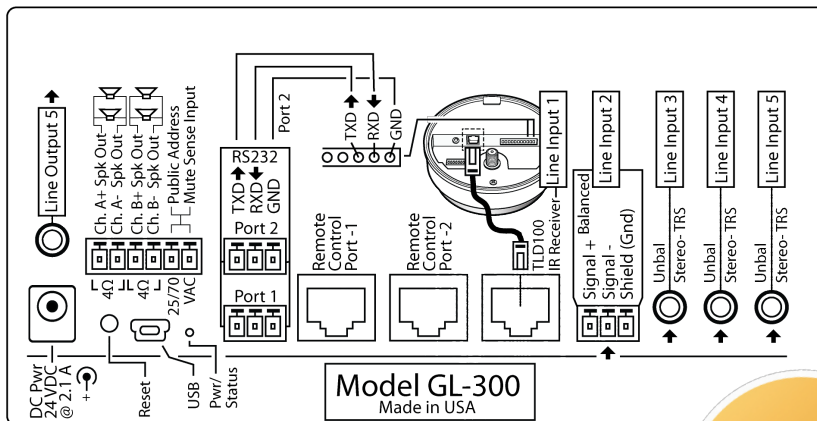

**Model GL-300**  
Made in USA



**Back View**

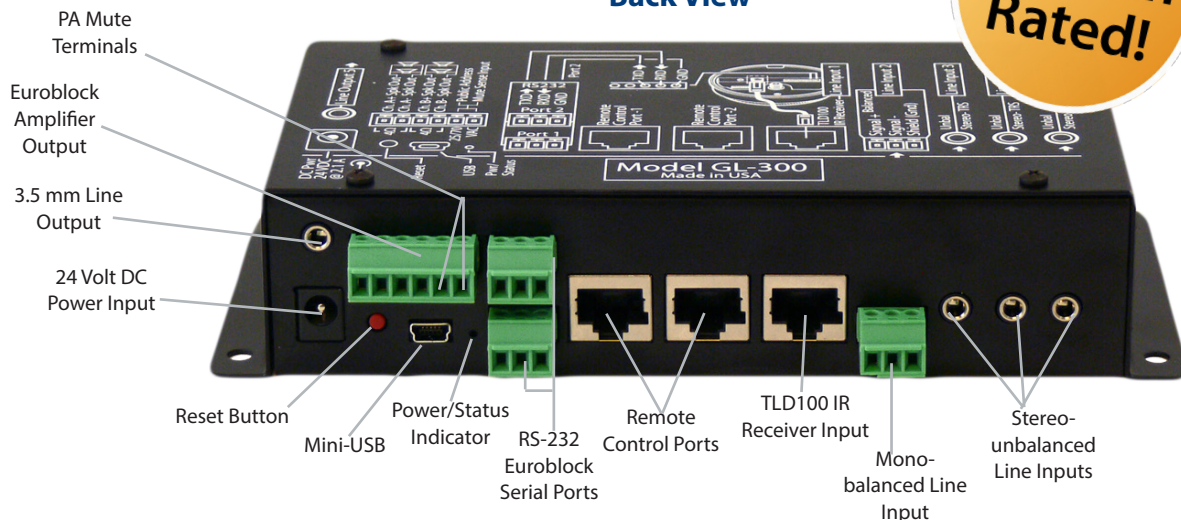

This plenum rated **GL-300** amplifier is perfect for seamless classroom integration. Controllable via RS-232, the compact size of this amplifier hides quietly in ceilings, enclosures or cabinetry. This amplifier also connects easily with other devices for quick installation.



**GL-300 Audio Solution**  
(accessories to GL-300 optional)

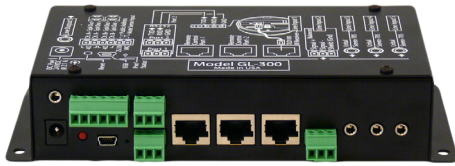

## GL-300 Amplifier Specifications

Line Inputs	For PC, DVD audio, MP3, auxiliary mic, or other multimedia sources 1 Line Balanced/unbalanced input (Euroblock) 3 Line unbalanced stereo inputs (3.5 mm) 1 Input connector for IR-Satellite/TLD100 (RJ45)
Line Outputs	Unbalanced (3.5 mm) Internal Network Audio
Equalizer	5-Band Equalizer
Mini USB	Control and configuration via software
Minimum Load Impedance	4 Ohms
Amplifier Type	92% Efficient Class D
Continuous Power @ 1% THD	32 Watts (16 Watts (rms) per channel x 2 channels @ 4 ohms)
Damping Factor	>50 up to rated power with 4 ohm load
S/N	>84 dB @ 20 Hz to 20 kHz at maximum output
CMRR	>80 dB
Protection Circuits	Thermal and Short Circuit protected
PA Connector	Connects to Public Address System and mutes amplifier during announcements
Control Port	RS-232, 3-pin screw terminal block header, RJ45 Remote Control Port (2) RS-232 Communication Ports: 1 port for integration with control systems or IR-Satellite/TLD100
External Power Supply	100-240 VAC, 50/60 Hz, 1.5A; 24 VDC, 2.5 Amps (nominal), regulated
Temperature/Humidity	Storage: -40 to 158°F (-40 to +70°C)/10-90% non-condensing
Enclosure Type	Metal, baked powder coated
Product Weight & Dimensions	1.25 lbs (0.57 kg) 6.44 (H) [7.34 with flanges] x 3.31 (W) x 1.56 (D) in. (163.51 [187.325 with flanges] x 84.14 x 39.69 mm)

*The SAFE System (patent pending) is an alert notification system not intended to be a life-saving device or prevent emergencies. Audio Enhancement, our agents, employees, subsidiaries, affiliates and parent companies are exempt from liability for any loss, damage, injury or other consequence arising directly or indirectly from the application of our equipment. In the event of misuse or malfunction of the SAFE System or any of its components, Audio Enhancement, our agents, employees, subsidiaries, affiliates and parent companies are exempt from liability for any loss, damage, injury or other consequence arising directly or indirectly therefrom.*

**SAFE System™**  
Compatible



[www.AudioEnhancement.com](http://www.AudioEnhancement.com) • 800.383.9362